



Polyprene Tank Installation and Mounting

PolyBilt Body Installation and Mounting

Congratulations on your purchase of a Polyprene® product from Pro Poly. Attached please find installation and mounting instructions for your tank or body. Please review and follow these instructions and contact us at 1-800-864-3817 with any questions.

Thank you again for your purchase and enjoy your product.

Pro Poly of American registered trademark
PolyBilt registered trademark



Pro Poly of America, Inc. (PPA) builds the finest tanks in the industry. When installed properly, the tanks are warranted for the life of the truck. Please follow these installation requirements. If you have any questions, please call customer service at (352) 629-1414.

INSTALLATION REQUIREMENTS

The tank has eyebolts installed in the lifting pegs for use in installation. Your lifting device should be connected to the eyebolts with a "sling" which has an angle of 90°.

Unless otherwise specified, the tank must be isolated from the subframe of the vehicle through the use of rubber strips with a minimum dimension of 1/4" x 2", 60 Durometer.

The tanks shall rest on a sub frame with 1 1/2" x 3" x 1/8" wall tubing or 3" x 4.1 # C channel at a minimum. The sub frame cross members must be spaced at a distance that would not allow for more than 400 square inches of unsupported area under the tank floor.

The tank must be cradled around the entire bottom perimeter and supported both front and rear as well as side to side to prevent tank from shifting during vehicle operation. You are responsible for adequately containing this tank.

One method of containment is a picture frame type cradle designed with a minimum of 2" x 2" x .25" steel or aluminum angle. Where aluminum or steel tubing and channel sub frames are incorporated in the body structure, the use of vertical corner angles having a minimum dimension of 4" x 4" x .25" thick x 6" high are permitted for cradling the tank.

Also, in addition to forward and aft containment and side to side containment, the tank must be restrained from vertical movement. One option is tank floor mounting blocks. The mounting blocks require minimum 3/8 – 16 stainless steel bolts which must not exceed 7/8" length above tank floor. The bolts must be used with springs for flexibility.

Hose floor loading must support 200 lbs. per square foot. Equipment such as generators and pumps must not be mounted directly to the tank top unless provisions have been provided by PPA in advance.

All tank connections must be of a flexible design.

All "T" type tanks with a rear step overhang exceeding 18" must have full length cross members 1 1/2" x 3" x 3/16" supporting the overhang. The cross members shall be isolated from the tank with rubber strips.

Do not drill holes or install fasteners on the tank surface without first obtaining approval from PPA.

Tanks over 1,000 gallons: max fill rate 1,000 gpm at max fill pressure 100 psi. Tanks under 1,000 gallons: max fill rate 500 gpm at max fill pressure 100 psi.

This sticker is a summary only and is not meant to replace our complete installation guide. Please see our complete Polyprene Installation Instructions for further clarification. You may obtain a copy of our Installation instructions at www.propolyamerica.com

THIS TANK INSPECTED FOR SHIPPING BY: _____

"Therefore, as we have opportunity, let us do good to all..." Galatians 6:10

TANK MOUNTING DESIGN AND SPECIFICATIONS

Your Polyprene tank must be adequately supported, contained and held in place. This document describes the most common methods in the fire industry to achieve these requirements. You are required to adequately support your Polyprene tank and keep the tank contained from forward and aft movement, side to side and vertical movement. Failure to abide by these requirements will void your Pro One warranty.

TANK SUBFRAME

The tank must be adequately supported on a tank subframe. The tank shall rest on truck body crossmembers that form a "subframe" with such additional cross members spaced at a distance that would not allow for more than 530 square inches of unsupported area under the tank floor. In cases where overall height of the tank exceeds 40 inches, cross member spacing must be decreased to allow for not more than 400 square inches of unsupported area.

Please assure that at least a 1" space is designed between the tank and the truck compartment walls as well as between any other polymer component and truck frame or body component.

FIGURE 1: SUBFRAME SPACING

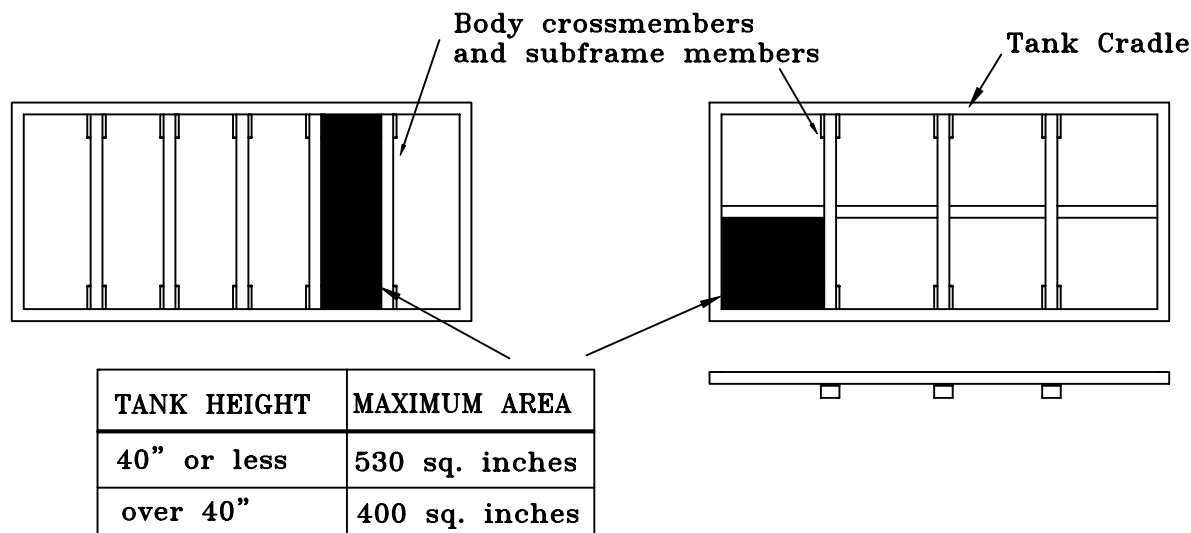

Cross members and subframe to be constructed of minimum 2" x 2" x .25" steel or aluminum (tubing or angle) so that the subframe can adequately support the tank and the weight of the water. (Water weighs 8.34 pounds/gallon.)

The tank must be isolated from the subframe through the use of rubber strips with a minimum dimension of .25" x 2" and a minimum Rockwell hardness of 60 durometer.

The tank subframe supports the tank and maintains tank integrity. In addition to the subframe support, the tank must be contained to prevent fore and aft shift, side to side shift and vertical movement during vehicle operation.

SIDE TO SIDE AND FORE TO AFT SHIFT CONTAINMENT

In addition to being adequately supported, the tank must be properly contained to avoid shifting during vehicle operation.

One method is the use of vertical angle brackets. Vertical angles can be used on all four corners of the truck subframe to contain the tank. The angles must be 6" high from the bottom subframe and be composed of 4" x 4" x .25" steel or aluminum. These should be at a 1/4" space from tank walls.

FIGURE 2: VERTICAL ANGLE POST

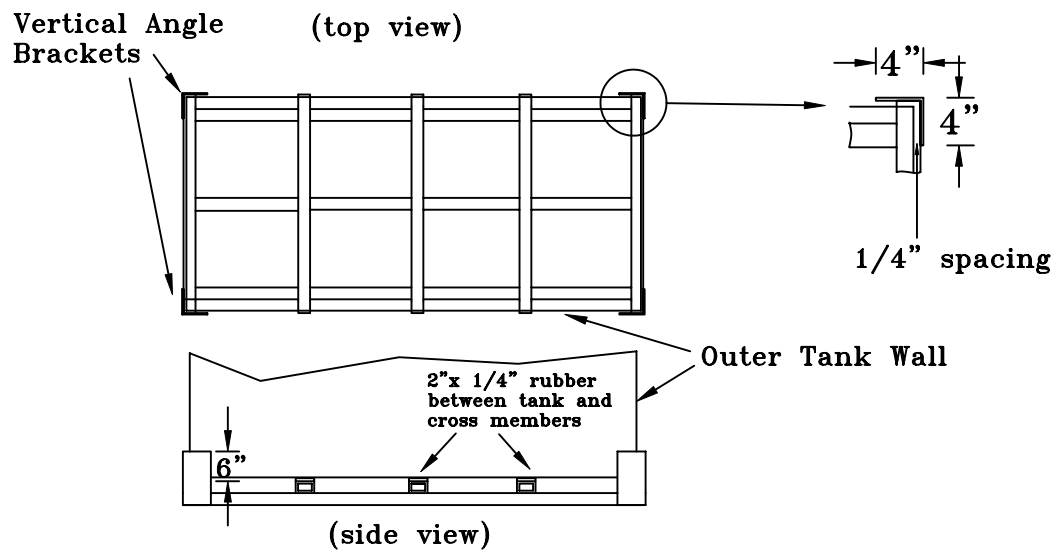

PICTURE FRAME CRADLE CONTAINMENT

Another method of containment is the picture frame cradle. A picture frame cradle utilizes a 2"x 2"x .25" steel or aluminum angle to provide a cradle for the entire perimeter of the tank. If the horizontal leg of the angle is positioned inward under the tank, a 1/4" rubber strip is needed to match the rubber on the cross members of the subframe. It is recommended to leave a 1/2" gap between cradle and tank.

FIGURE 3: PICTURE FRAME CRADLE

(top view)

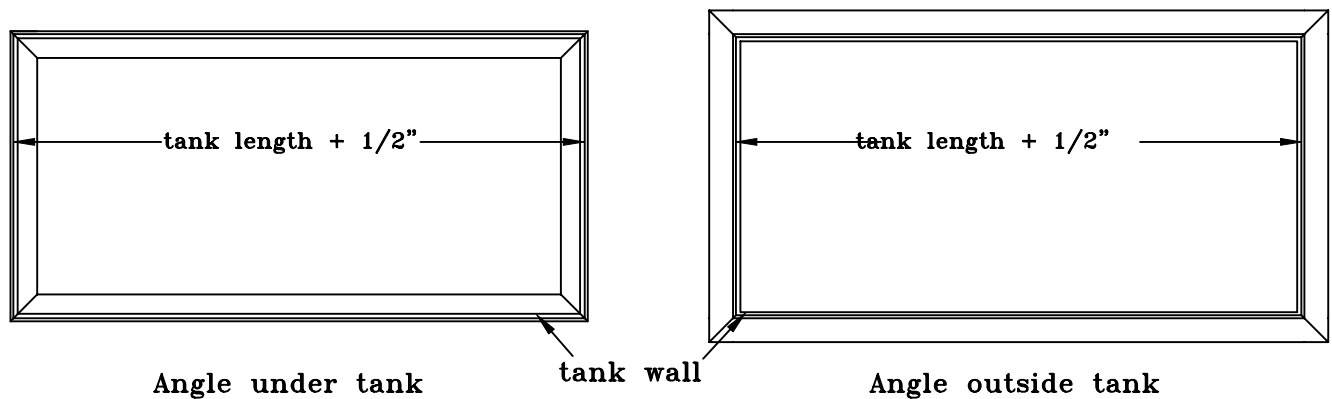

VERTICAL TANK SHIFT

In addition to being properly supported and contained to prevent side to side and fore to aft shift, all tanks must be "held down" to avoid damage to the tank during vehicle operation. This is particularly a concern when the tank is empty. Although the tank is designed as a free-floating suspension unit, it is required that the tank have adequate hold down restraints to minimize movement during vehicle operation. If proper retention has not been incorporated into the apparatus hose floor structure, an optional mounting restraint system shall be located on top of the tank, halfway between the front and rear on each side of the tank. These stops can be constructed of steel, stainless steel, or aluminum angle having minimum dimensions of 3"x 3"x .25" and shall be approximately 6 to 12 inches long. These brackets must incorporate a hard rubber isolating pad with a minimum thickness of .25" affixed on the underside of the angle. The angle should then be bolted to the body side wall of the vehicle while extending down to rest on the top outside edge of the upper side wall of the tank.

FIGURE 4: TANK HOLD DOWN

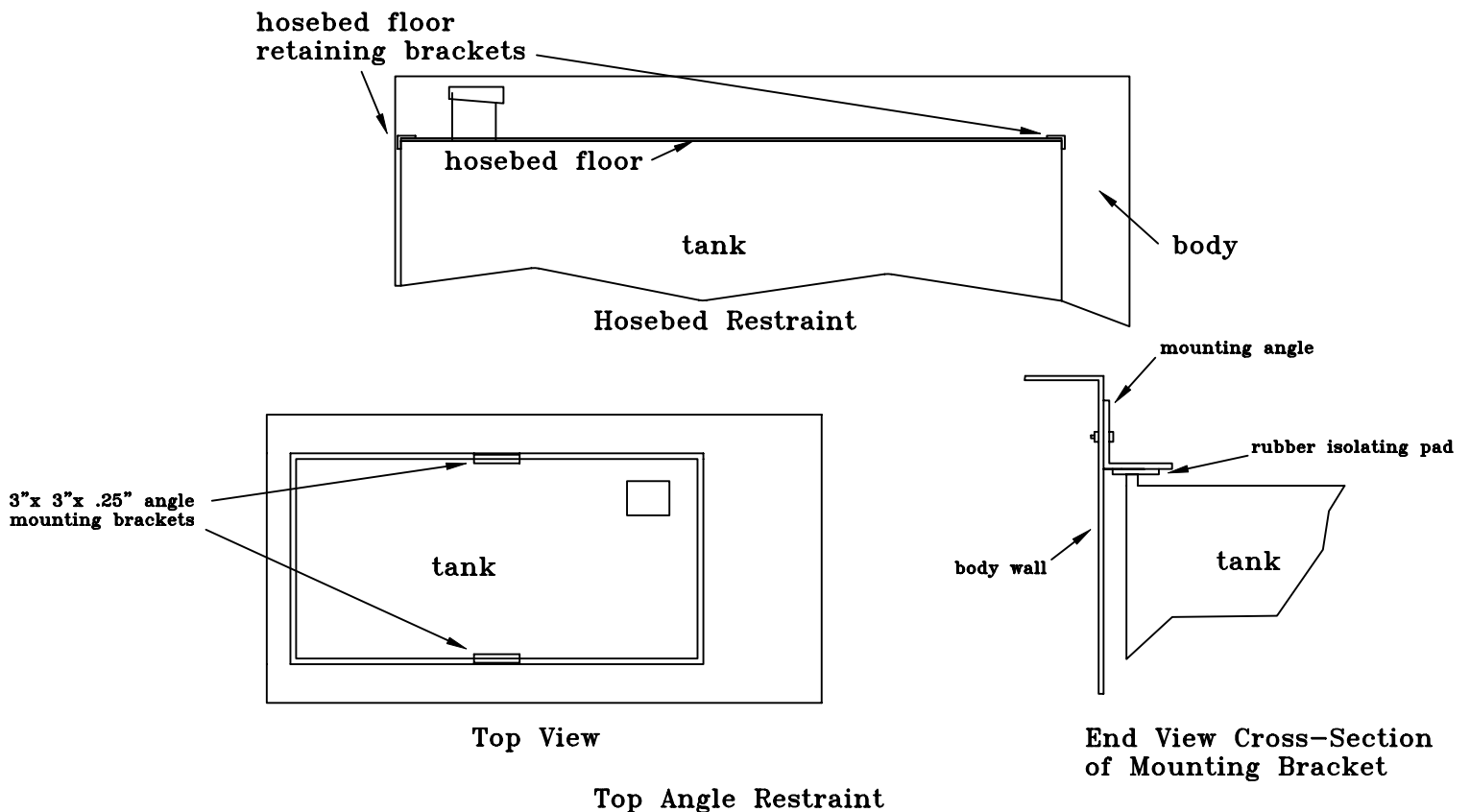

INTERNAL MOUNTING BLOCKS

An internal mounting block design can also be incorporated to prevent vertical tank shift. Mounting blocks with countersunk threaded nuts can be made accessible if specified in the design of the tank. The mounting blocks are similar to those shown in the PolyBilt mounting procedure in figure 5. **IMPORTANT: BOLTS SHALL PROTRUDE INTO BOTTOM OF TANK NO MORE THAN 3/4".** Failure to comply may result in a non-warranted leak.

POLYBILT MOUNTING

PolyBilt unibody/tank products are mounted using the exclusive Steel Flex™ mounting system. This system requires an independent subframe, as set forth on page 1 herein, and spring loaded assembly from subframe to chassis. PolyBilt bodies are equipped with Polyprene angle body mounts which connect the integrated compartment to the subframe outrigger and internal mounting blocks with an integral tank design. Like Polyprene tanks, PolyBilt bodies must be contained and supported. Please see the following methods of support and tank restrain. Both angle body mounts beneath the compartment floors, as well as integral tank mounting blocks must be fully utilized to prevent PolyBilt Body from shifting on the subframe.

FIGURE 5: STEEL FLEX™ MOUNTING SYSTEM

Integral Tank Mounting
(tank hold down blocks from integrated tank to subframe)

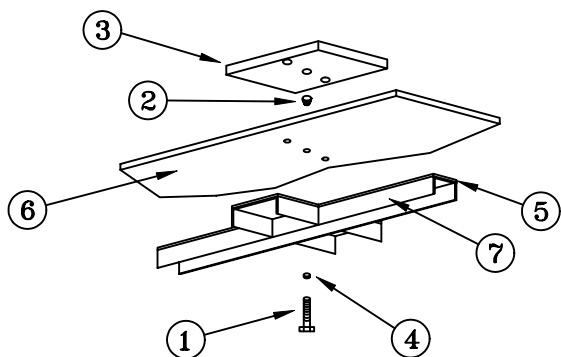

Polyprene Angle Body Mount
(from compartment to subframe)

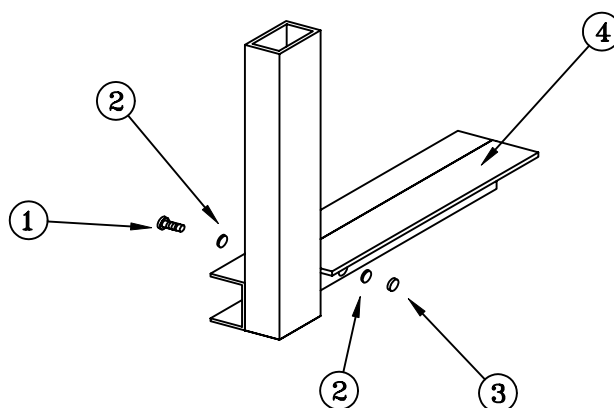

REP. NO.	DESCRIPTION
1	Hex Head Cap Screws 3/8"x1-1/2"Lg Grade 8
2	Stainless Steel Tee Nut 3/8"
3	Inside Tank Cover Plate
4	Flat Washer 3/8"
5	1/4" Rubber Reinforced Isolating Pad
6	Bottom of Body
7	Subframe
8	1/2"x4" Metal Block
9	4"x10"x1/4" Forward Plate

REP. NO.	DESCRIPTION
1	Hex Head Cap Screws 3/8"x1-1/2"Lg
2	Flat Washer 3/8"
3	Nylon Insert Lock Nut 3/8"
4	Polyprene Outrigger

In addition your subframe should contain a forward stop as identified below.

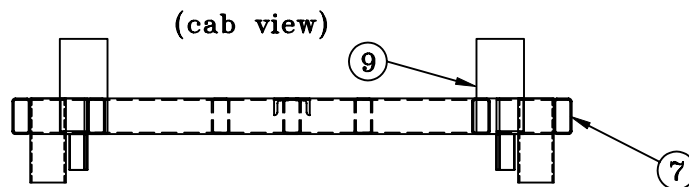
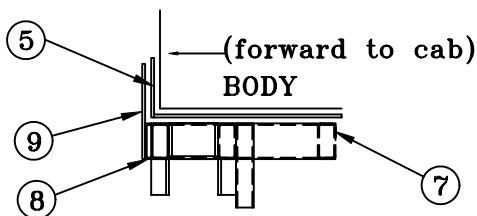

Bracket Assembly for Mounting Subframe to Chassis

The subframe is mounted to the frame rail using the spring loaded design, identified in the following illustration.

ITEM	QTY.	MATERIAL
1	1	UPPER BRACKET
2	1	LOWER BRACKET
3	10	WASHER
4	2	BOLT
5	4	LOCKNUT
6	2	SPRING
7	2	BOLT

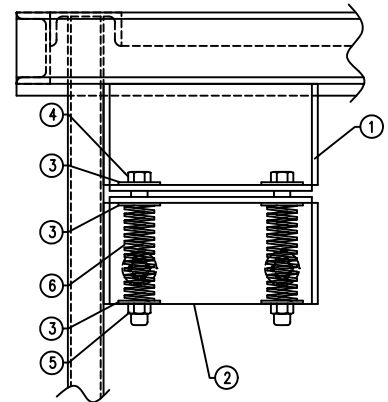
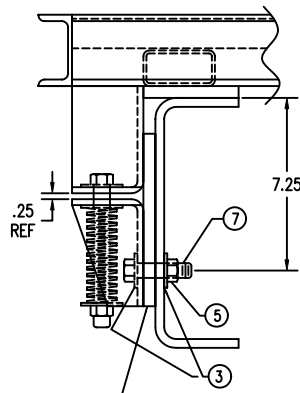

SPACER DEPENDENT ON CHASSIS FRAME WIDTH

ASSEMBLY NOTE: PRELOAD SPRING 3/16"

